



14+



11



2m



1 = 5,79m  
2 = 4,76m  
3 = 3,02m

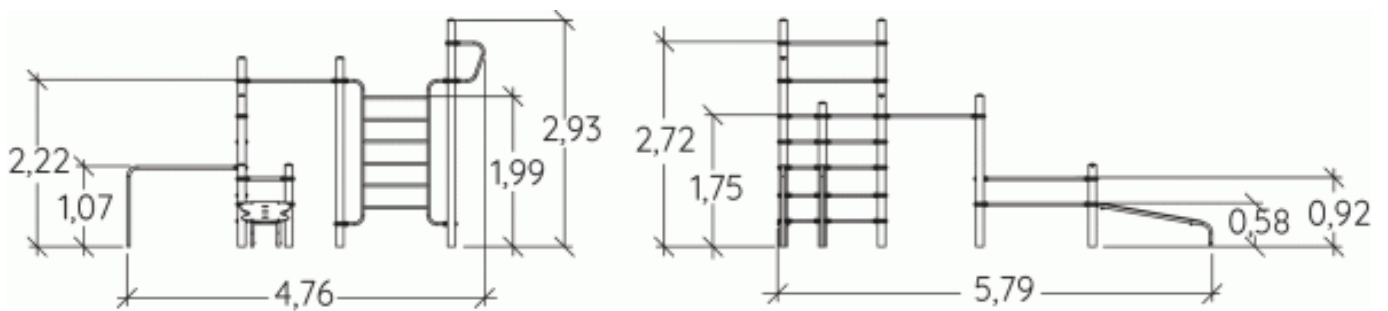
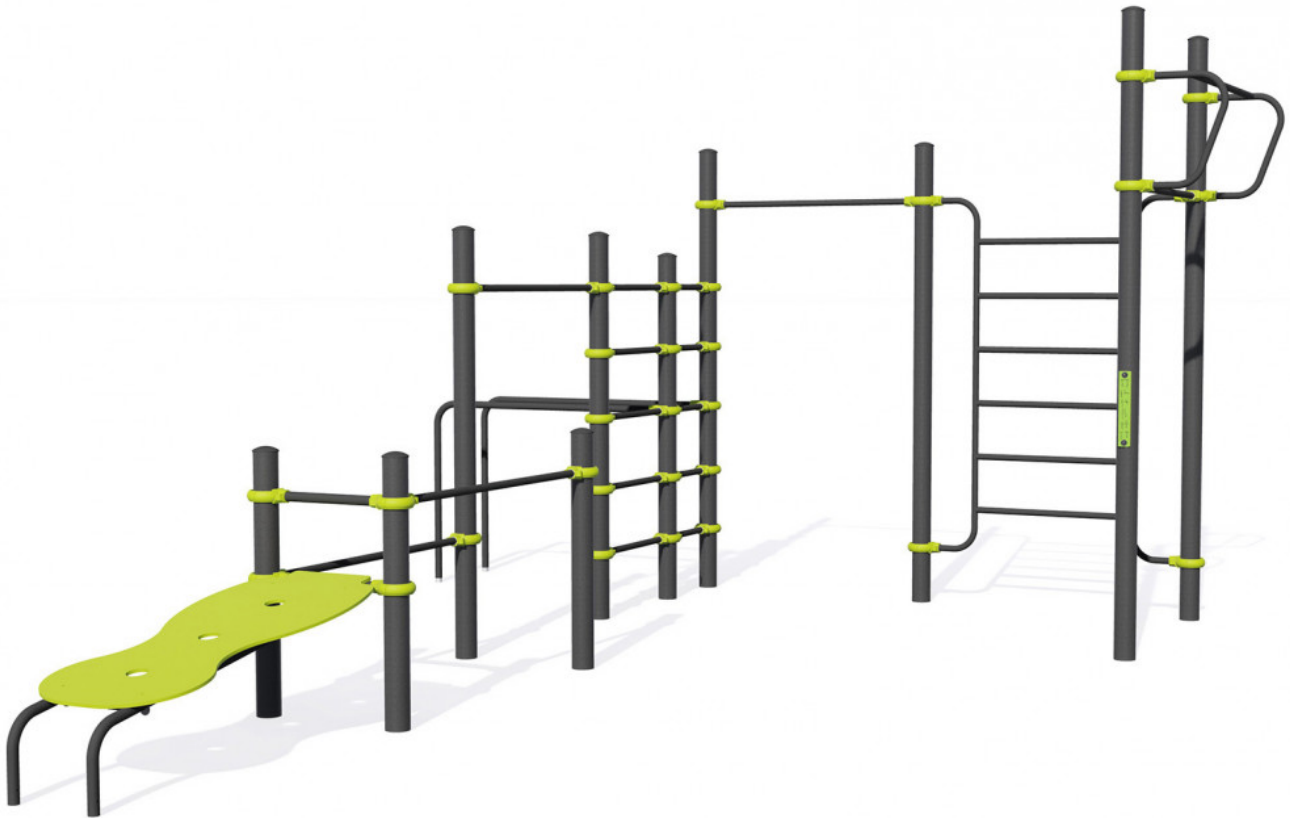

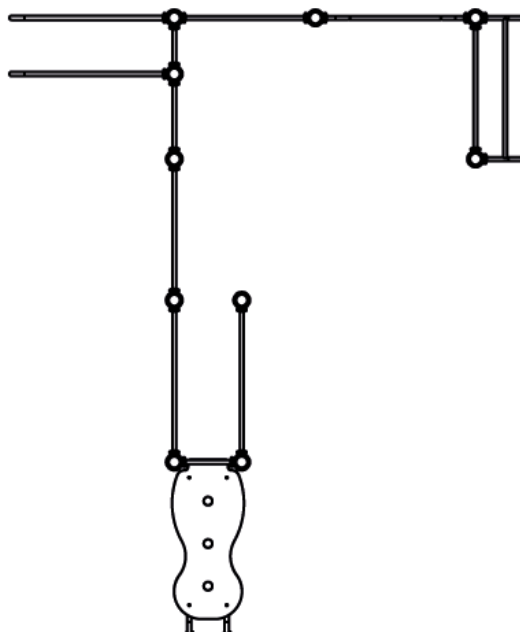

## Elementos constituyentes





## Instalación del equipamiento

Zona de impacto: Superficie de suelo mínima requerida

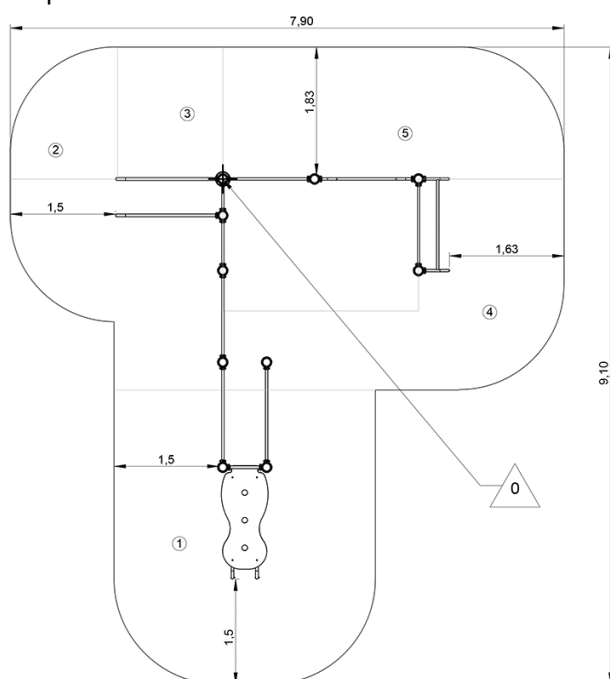
-  Zona de impacto
-  Espacio libre



		
1	0,95m	15m <sup>2</sup>
2	1,1m	2,5m <sup>2</sup>
3	1,2m	3m <sup>2</sup>
4	1,7m	16,5m <sup>2</sup>
5	2m	14m <sup>2</sup>



2



07h00



1.9m<sup>3</sup>



51m<sup>2</sup>



322kg



28kg

