



14+



9



1,7m



1 = 5,26m
2 = 3,26m
3 = 2,32m



Discapacidad motriz
Discapacidad sensorial
Discapacidad mental

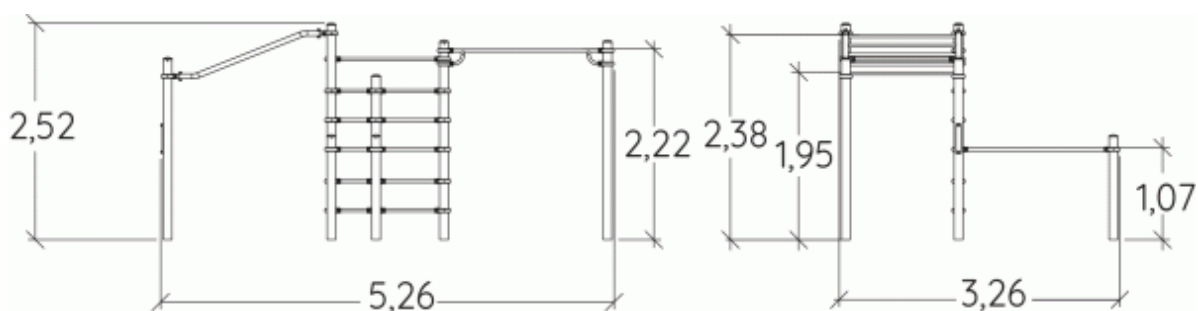
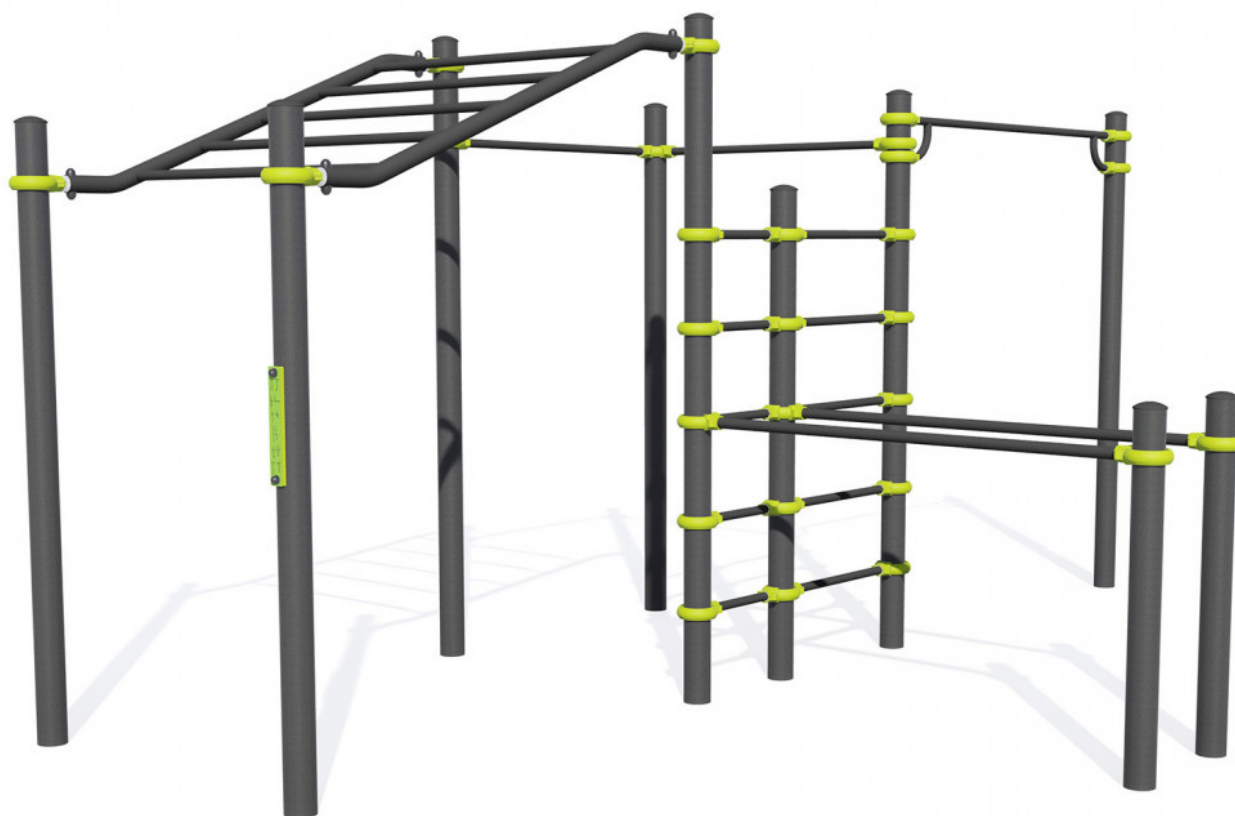

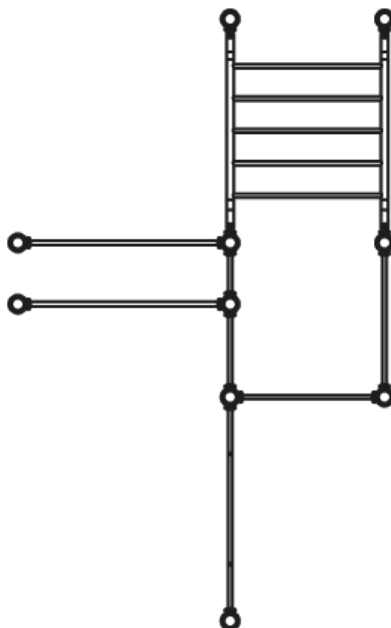

Elementos constituyentes



Instalación del equipamiento

Zona de impacto: Superficie de suelo mínima requerida

-  Zona de impacto
-  Espacio libre

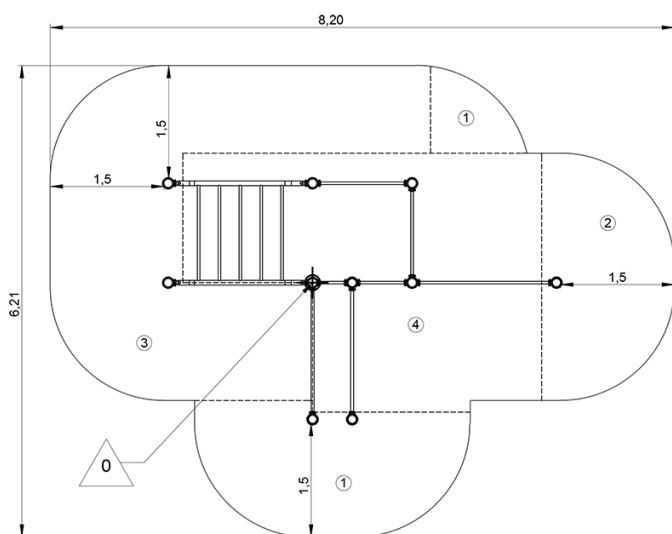

| | | |
|---|------|------------------|
| 1 | 1,1m | 20m ² |
| 2 | 1,2m | 5m ² |
| 3 | 1,7m | 13m ² |



3



05h00



1.5m³



38m²



284kg



22kg

