



14+



8



2m



1 = 7,13m
2 = 1,46m
3 = 2,32m



Discapacidad motriz
Discapacidad sensorial
Discapacidad mental

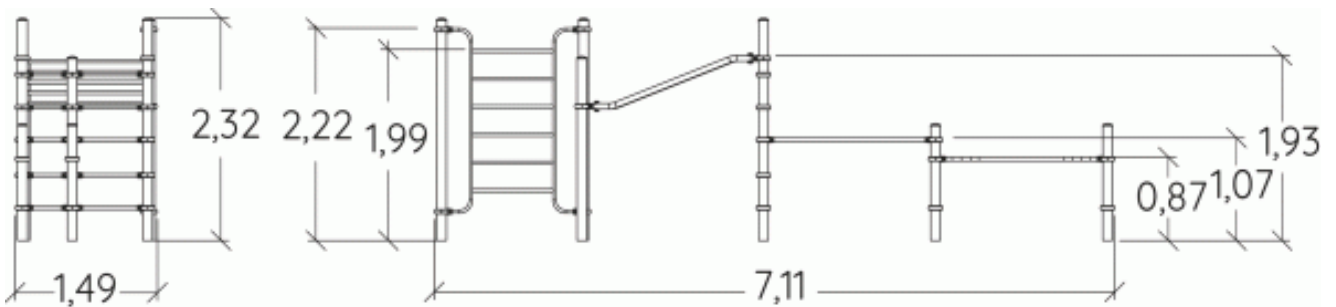
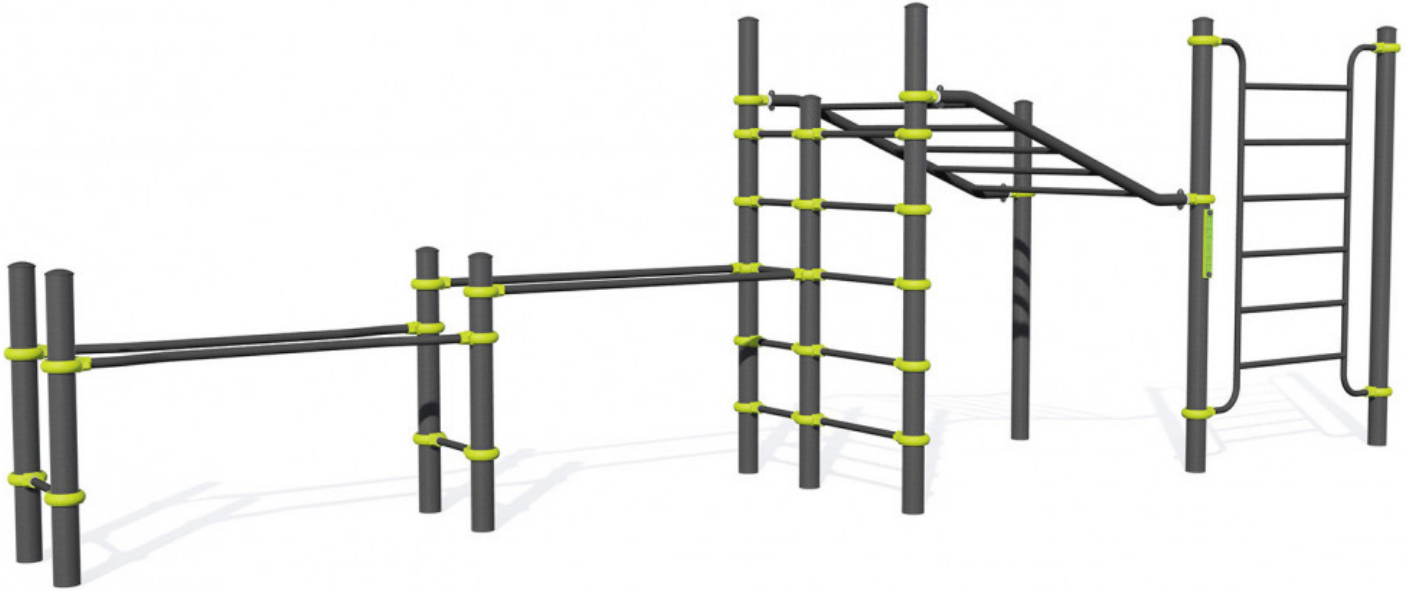
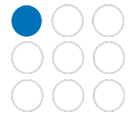

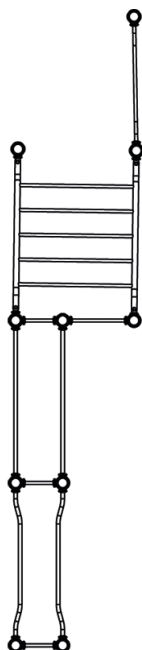

Elementos constituyentes



Instalación del equipamiento

Zona de impacto: Superficie de suelo mínima requerida

-  Zona de impacto
-  Espacio libre

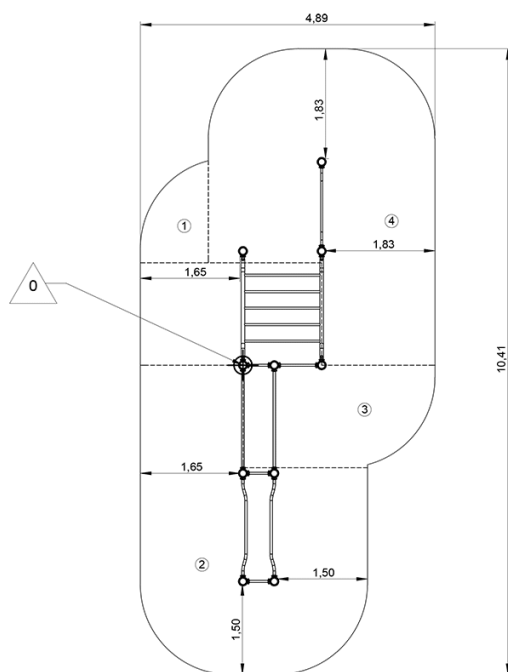

| | | |
|---|------|-------------------|
| 1 | 0,9m | 1,5m ² |
| 2 | 1,1m | 15m ² |
| 3 | 1,7m | 10m ² |
| 4 | 2m | 16m ² |



3

07h00

1.5m³

42.5m²

282kg

22kg



EN

16 630